

Low-Complexity Beamforming Techniques for IEEE 802.11n WLANs

Christos Papathanasiou, Iordanis Koutsopoulos and Leandros Tassioulas

Centre for Research & Technology Hellas

University of Thessaly, Greece

Email: (cpapa@uth.gr, jordan@uth.gr, leandros@uth.gr)

Abstract: - The impetus of the present study is to describe a downlink beamforming method that increase spectrum efficiency and significantly reduces implementation complexity and power consumption compare to beamforming technique at each sub-carrier, proposed in the ongoing IEEE 802.11n standardization. In our scheme, common transmission weight vectors are used at a set of users in all sub-carriers. Our strategy consists of simultaneously designing downlink beamformers to multiple co-channel sets of users under the constraint on providing at least a prescribed received Signal-to-Interference – plus – Noise Ratio (SINR) to each intended receiver. We assume that the instantaneous channel gains are known at the Access Point (AP) for all users. Simulation results show substantial gain for our proposed algorithms in IEEE 802.11n wireless access networks.

I. INTRODUCTION

The future growth of wireless communications in the decade to come focuses on a large variety of multimedia applications. Requirements of high spectral efficiency, high throughput and low latency are essential for the wireless delivery of such content in real time applications. Currently 802.11 Task Group n (802.11 TGn) makes an effort to define modifications to physical and MAC (Medium Access Control) layer aiming to provide a minimum at 100 Mbits/s throughput at the MAC SAP (Service Access Point) which means that the transfer rate over air will be 200 Mbits/s [1]. In order to increase the transfer rate of wireless system, MIMO technology and wider bandwidth channels are required [2].

Various references for downlink MIMO-OFDM systems have been proposed. Qualcomm's 802.11n proposal includes a physical layer (PHY) strategy, mentioned as Eigenvector Steering (ES), which calculates the optimum transmit and receive parallel stream vectors for each sub-channel from Singular Value Decomposition (SVD) of channel matrix [3]. The same philosophy is documented in [4] where the transmission scheme is named Eigenbeam – Space Division Multiplexing (E-SDM).

The concept of this paper is to greatly improve the frequency utilization by extending a MIMO-SDMA-OFDM system while focusing on the IEEE 802.11n standard. Although enough publications are referred to the design of MIMO-OFDM systems, a Downlink Multi-users MIMO-SDMA-OFDM system served by one AP is to our

knowledge still lacking in the literature. OFDM is characterized by its simplicity. OFDM transmitters are low cost due to the ability of replacing the banks of sinusoidal generators by Discrete Fourier Transform (DFT) and as a consequence the implementation complexity of the modem is reduced. The sub-carriers are neither individually filtering nor amplifying. In order to achieve a reasonable complexity, the beamformer must multiply by the same complex weights all sub-carriers. In E-SDM, the AP uses eigenvectors of channel matrix as transmission weight vector and implementation is based on Digital Signal Processing (DSP) at the baseband chip. The precoder of the eigen beamforming is done on every sub-carrier before the information is sent to IFFT module. This implementation suffers from increased complexity and places tough performance criteria on the Digital to Analog (D/A) converter in order to provide accurate delay. Our architecture supports RF-beamforming which offers low cost hardware, more capabilities and particularly higher beam pointing accuracy. Also, our approach has advantages with respect to lower power consumption as signal process is reduced. Additionally, at baseband beamforming scheme, linearity and dynamic range of the Intermediate Frequency (IF) stage and D/A converter will also have to be substantially higher leading to higher power consumption. The efficiency of the proposed cost-saving and less complex solution is studied by simulation with real values (non-normalized) derived from IEEE 802.11n channel model [5]. The simulation includes all the main propagation effects such path loss, shadowing, delay spread, spatial correlation and Doppler effects.

The core idea of our proposed design is the following: consider an AP \mathbf{a} , where the transmitter is equipped with M_t antennas and there are K users. In order to increase throughput, SDMA is used. According to their locations, the users are divided in g sets. Downlink beamformers are designed for the co-channel sets of users under quality of services (minimum attained signal to interference plus noise ratio at each receiver). The goal is to maximize total transmission rate. We define the operation frequency of AP \mathbf{a} f_a at the center of channel band. This is not a link-by-link optimization problem and therefore hasn't large computation cost. For each set of users, multi-user diversity can be exploited to find a subset of good sub-carriers to meet Quality of Services (QoS) requirement. The different sub-carriers of each set can be allocated to

This work is supported by the European Commission funded project OPNEX (IST-224218).

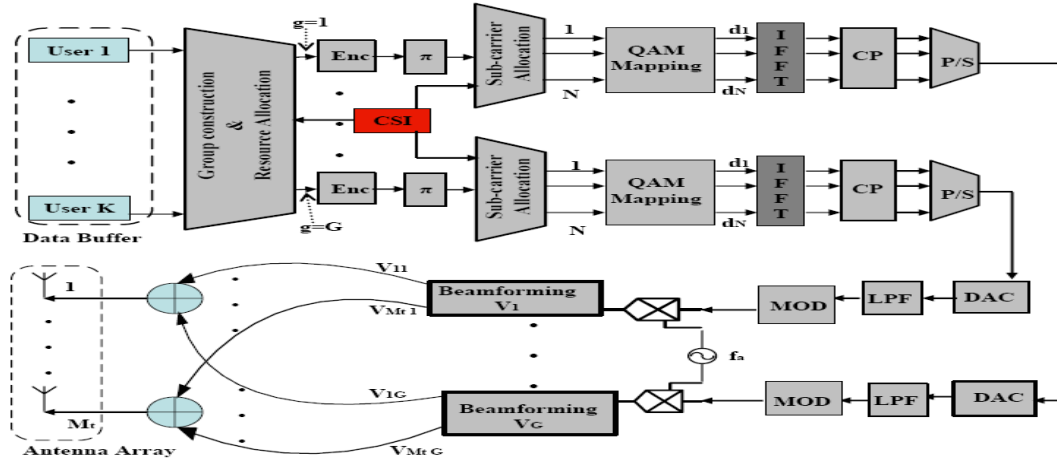

Figure 1. The PHY transmitter model for A

different users (OFDMA). By adaptively employing different modulation modes on the sub-carriers according to SINR, we enhance the system performance. The drawback in such design of sets is that the receivers are found at different locations, near or away from AP. The constraint of minimum guarantee SINR for each receiver must be satisfied. In order to improve the performance of our system, multiple antennas at the receiver are proposed. Coherent combination of diversity paths increases SNR in comparison to just a single antenna receiver. This growth of SNR is called "array gain". The AP and users exploit Channel State Information (CSI) to form the antenna weights. In sort-rang scenario like WLAN, CSI is feasible because of low mobility.

The paper is organized as follows: in the next section, we define the system model. In section III downlink beamforming MIMO-SDMA algorithms are developed. In section IV performances of proposed algorithms are extensively simulated and are finally compared to currently used strategies. Section V concludes this article.

II. SYSTEM MODEL

TGn supports 20 MHz bandwidth where the spectrum is limited and 40 MHz with two adjacent spectral channels. This technique which combines two adjacent channels of 20 MHz into one of 40 MHz is called channel bonding.

TABLE I. MODE-DEPENDENT PARAMETERS

Mode	Modulation	Coding Rate (R)	Coded bits per subcarrier	Minimum Sensitivity (dBm)
1	BPSK	1/2	1	-80
2	QPSK	1/2	2	-77
3	QPSK	3/4	2	-75
4	16-QAM	1/2	4	-72
5	16-QAM	3/4	4	-68
6	64-QAM	2/3	6	-64
7	64-QAM	3/4	6	-63
8	64-QAM	5/6	6	-62

The high data rate digital signal is converted into 48 overlapping low data rate frequency sub-bands using an Inverse FFT. Each sub-channel occupies 312.5 KHz and is not individually filtered. The total number of generated sub-carriers is 64. There are 4 pilot tone channels and one null in the center of the band. In order to reduce adjacent channel interference, the outer 12 sub-channels are zeroed. Physical layer (PHY) modes in 20 MHz channel width with different coding and modulation schemes for IEEE 802.11n are present in Table I.

We study a system with a single AP a and K users. Both AP and each user are equipped with array antennas M_t and M_r , respectively. Consider a total of $1 \leq G \leq K$ sets of users $\{G_1 G_2 \dots G_G\}$, where G_g contains the indices of receivers participating in set g , $g \in \{1 2 \dots G\}$. Each receiver belongs to a single set $G_g \cap G_m = \{\}$ with $g \neq m$ and $\sum_{g=1}^G |G_g| = K$. The schematic model for the AP is depicted in figure 1. At the transmitter, all user's packets are sent to group construction module. This module drives the data into convenient set of users and resource allocation algorithm find the number of assigned sub-carriers at each user from the total number of data sub-carriers. In figure 1, $G \leq M_t$ beamforming modules are used and therefore up to G beams are possible to be constructed. At the receiver, the uncoupled operation is evaluated to decode the information bits for every user belong to set g . To provide high data rate, Automatic Modulation and Coding (AMC) are adopted on every sub-channel. According to SNR_n^g for the n sub-carrier belongs to set g , different modulation schemes of AMC can be implemented. If SNR_n^g threshold is guaranteed, no packet errors are assumed. The packet loss only happens when the buffer of user is overflowed.

Let the channel for user k : at operation frequency f_a is frequency-flat quasi-static and time-invariant; propagation loss and phase shift are described by $H_k^{f_a} M_r \times M_t$ channel matrix. The operation frequency of our downlink beamforming optimization problem is defined at the center

of band, where according IEEE 802.11n sub-carrier is null. Multipath delays cause frequency selective fading and par consequence the estimated channel matrices $H_k^{f_a}[1]$ to $H_k^{f_a}[N]$ correspond from sub-carrier 1 to N perhaps present large gain variation in the same band. In order to overcome these problems, $H_k^{f_a}$ is taken as the average channel matrix for all sub-carriers.

$$H_k^{f_a} = \frac{1}{N} \sum_{i=1}^N H_k^{f_a}[i] \quad (1)$$

Considering $v_g^{f_a}$ of size $M_f \times 1$ the beamforming weight vector applied to the transmitter, the total radiated power is

$$P_{tx}^{f_a} = \sum_{g=1}^G \|v_g^{f_a}\|_2^2 \quad (2)$$

If $U_k^{f_a} M_r \times M_r$ is the matrix applied at user k , then the Rx power at the receiver k is

$$P_k^{f_a} = \left| (U_k^{f_a})^H H_k^{f_a} v_g^{f_a} \right|^2 \quad (3)$$

Suppose that the noise at receiver k is zero mean with variance $(\sigma_k^{f_a})^2$. The noise power is

$$N_k^{f_a} = (\sigma_k^{f_a})^2 \|U_k^{f_a}\|^2 \quad (4)$$

III. DOWNLINK BEAMFORMER DESIGN

A. Receiver Antenna Arrays

The receiver antenna arrays have a properly determined beam pattern. They steer the beams to enhance the total power in all reflected paths in a scattering environment. Array gain is achieved via coherent combining of the signal paths. The proposed strategy is based on ES or E-SDM. H_k^n can be diagonalized as $H_k^n = U_k^n D_k^n (V_k^n)^H$. The columns $u_{ki}^n (v_{ki}^n)$ of $U_k^n (V_k^n)$ are the optimum weights of Rx antenna arrays (Tx antenna arrays) for i th eigen mode [6]. E-SDM forms beams using eigen-vectors and can configure a spatially orthogonal MIMO channel that is a channel without crosstalk. Therefore, receiver antenna arrays form beams using eigen-vectors and expect to capture all possible orthogonal spatial streams derived from scatters which are found in the neighborhood of transmitter and receiver. SVD must be evaluated at the receiver. The calculation load increases proportionally according to the number of sub-carriers. But the channel in frequency domain is smooth. The adjacent sub-carriers are highly correlated because we multiply all sub-carriers by the same complex weights. This correlation reduces the calculation load. One can estimates U_k^n matrix in one specific sub-carrier n by interpolation and smoothing over adjacent sub-carriers. In E-SMD technique, the beams applied at the transmitter are the vectors V_k^n at each sub-carrier n . The equivalent channel after beamforming is not still remaining smooth leading to higher computation load and high power consumption.

B. Beamforming design for AP

We solve the general power minimization problem (subject to SINR constraints) of simultaneously designing beamformers for several co-channel multicast sets of users. This problem was studied in [7] for frequency flat channel and can be formulated as a convex optimization problem. However, the solution is considered for single antenna receivers. We extended this design taking account that the remote users have multiple antennas (MIMO system). Finally, we transform the transmit power minimization problem in to a throughput maximization under the constraint on the total transmitted power. Given received vector U_k for all users of set g , the posed problem is to generate an optimal downlink beamforming at AP a, minimizing at the same time the total transmitted power and guarantying prescribed SINR constraints γ_k at each user of set g .

$$\begin{aligned} \mathcal{Q} \quad & \min_{\{v_g \in C^{M_t}\}_{g=1}^G} \sum_{g=1}^G \|v_g\|_2^2 \\ \text{s.t.} \quad & \frac{|U_k^H H_k v_g|^2}{\sum_{l \neq g} |U_k^H H_k v_l|^2 + \sigma_k^2 \|U_k\|^2} \geq \gamma_k \\ & \|U_k\|^2 = 1 \quad \forall k \in \{1 \dots K\} \quad \forall g \in \{1 \dots G\} \end{aligned}$$

This problem was found NP-hard for general channel vector [7,8]. Let's introduce $r_k = U_k^H H_k M_r \times M_r$ complex vector, define $V_g = v_g v_g^H$, $R_k = r_k^H r_k$ and use $|r_k v_g|^2 = v_g^H r_k^H r_k v_g = tr(V_g R_k)$.

The problem \mathcal{Q} is transformed as

$$\begin{aligned} \mathcal{Q}' \quad & \min_{\{V_g \in C^{M_t \times M_t}\}_{g=1}^G} \sum_{g=1}^G tr(V_g) \\ \text{s.t.} \quad & \frac{tr(R_k V_g)}{\sum_{l \neq g} tr(R_k V_l) + \sigma_k^2} \geq \gamma_k \\ & V_g \geq 0 \quad V_g = V_g^H \quad rank(V_g) = 1 \\ & \forall k \in \{1 \dots K\} \quad \forall g \in \{1 \dots G\} \end{aligned}$$

The constraint $rank(V_g) = 1$ is applied from the fact that $V_g = v_g v_g^H$. Constrains $V_g \geq 0$ and $V_g = V_g^H$ mean that V_g is symmetric, positive, semidefinite matrix. In general case, the constraint $\{rank(V_g) = 1\}_{g=1}^G$ is not convex [8]. Ignore the associated non convex constraints, the original non-convex Quadratically Constrained Quadratic Programming (QCQP) problem \mathcal{Q} relaxed to a suitable Semi Definite Programming problem (SDP). The first advantage of using SDP is that we have a convex optimization problem and hence it has not local minima. The second one is that problem can be efficiently solved by any SDP solver, such as SeDuMi [9], based on interior point methods. Our problem can be expressed in the standard prima form used in SeDuMi. It consists of G variables $M_t \times M_t$ and M inequality constraints. SeDuMi is an iterative algorithm. Therefore, the complexity per iteration is $O((GM_t^2 + K)^3)$ and

for solution accuracy ω SeDuMi gives $O\left(\sqrt{GM_t^2 + K} \log\left(\frac{1}{\omega}\right)\right)$ worst-case iteration bound. The relaxed problem provides only lower bounds on the optimal solution $\{v_g^{\text{opt}}\}_{g=1}^G$ due to the fact that V_g^{opt} will not be rank – one in general. A randomization procedure is employed in [8] to generate candidate beamforming vectors v_g . This procedure is mentioned as $\text{rand}\mathcal{C}$. At the beginning, SVD is used in $V_g^{\text{opt}} = U \Sigma^{\frac{1}{2}} U^H$ and $v_g = U \Sigma^{\frac{1}{2}} w_g$ is put, where w_g is a Gaussian variable with $w_g \sim N(0, 1)$ to insure that $E[v_g v_g^H] = V_g^{\text{opt}}$. From computing feasible points, the vector with minimum $\|v\|_2^2$ is chosen.

The goal is now to maximize the transmit and the receive vectors such that the SINR is maximized subject to a constraint on the total transmitted power P_{max} . We introduce weighting transmit and receive vectors $v'_g = P_g v_g$ and $U'_k = c_{rx}^k U_k$. P_g and c_{rx}^k denote the power boost factors for multicast set of users g . SINR at each user k is

$$SINR_k = \frac{(P_g)^2 |U_k^H H_k v_g|^2}{\sum_{l \neq g} |U_k^H H_k v_l|^2 + \sigma_k^2 \|U_k\|^2}$$

In practice, optimization problem \mathcal{Q} constructs orthogonal beams in order to minimize co-channel interference $\sum_{l \neq g} |U_k^H H_k v_l|^2$. Then, the constant P_g is chosen as large as possible. The constant c_{rx}^k does not influence SINR and is therefore chosen as $c_{rx}^k = 1$. We distinguish two marginal cases: a) Co-channel interference is dominated $\sum_{l \neq g} |U_k^H H_k v_l|^2 \gg \sigma_k^2 \|U_k\|^2$ and excessive transmit power improves less SINR factor. b) One set of users is formed, $\sum_{l \neq g} |U_k^H H_k v_l|^2 = 0$ and SINR is multiply by $(P_g)^2$. In this way, for each candidate set of beamforming vectors, a multi-group power control (\mathcal{MGPC}) problem is solved.

$$\begin{aligned} \mathcal{MGPC} \quad & \max_{\{P_g \in \mathcal{R}\}_{g=1}^G} \sum_{k=1}^K \{P_g \alpha_{g,k} - \sum_{l \neq g} P_l \alpha_{l,k}\} \\ \text{s.t.} \quad & \frac{P_g \alpha_{g,k}}{\sum_{l \neq g} P_l \alpha_{l,k} + \sigma_k^2} \geq \gamma_k \\ & \sum_{g=1}^G \beta_g P_g \leq P_{max} \\ & \forall g \in \{1 \dots G\} \quad P_g \geq 0 \end{aligned}$$

where $\beta_g = \|v_g\|_2^2$, $\alpha_{g,k} = |v_g^H R_k v_g|$. This is a Linear Program (LP) and can be solved by SeDuMi with the computational cost being negligible.

IV. SIMULATION RESULTS

For validation reasons, we apply the proposed algorithms to a cell which is represented by a circle radius R and served by an AP at the center of cell. Transmit power of

AP is $P_t = 250mW$ while cell radius is considered to be equal to $R = 100m$. The system simulation is implemented in MATLAB environment. We assume that the number of transmit antennas at the AP is four ($M_t = 4$), the number of receive antennas at user station is four ($M_r = 4$). Uniform Linear Arrays with half wavelength spacing are used at both ends. Operation band is 20 MHz in 5GHz spectrum and the number of data sub-carriers is $N = 48$. Channel matrix H_{LOS} is computing with a break point $d_{BP} = 5m$, a path loss exponent $n = 3$, a shadowing deviation $\sigma_{\psi dB} = 4dB$ and a Rician K-factor $K = 3$ according IEEE 802.11n channel model in B environment [5]. Channel matrix H_{NLOS} is simulated as model B with MATLAB implementation available from L. Schumacher [10]. Users are placed in random locations, following a Uniform Distribution. We run downlink beamforming optimization problem (SDP, relaxation, randomization and power control) for 107 samples of time varying channel B due to Doppler effect. In indoor wireless systems, transmitters and receivers are stationary and people are moving. Also, 1000 randomization samples are generated. For the simulated channel matrices $H_k \quad \forall k \in \{1 \dots K\}$ we use the narrowband assumption, which implies that the signal seen at the receiver is a summation of all channel taps. This assumption is valid for our system based on OFDM modulation. The received SINR constraints are set to $\gamma_k = 15dB$ and the noise power at user k : $\sigma_k^2 = -95dBm$. Average PHY data rate is achieved if we allocate the same number of sub-carriers to each user. In IEEE 802.11n channel model, clustered structure of the propagation environment is assumed. More specifically, there is significant local scattering around both the AP and users, causing uncorrelated fading at each end of the MIMO link. Angular characteristic of users' position doesn't offer information for simulation. Only distance between AP and users is inserted for computing H_k .

Figure 2 shows the average physical data rate over 107 channel varying samples when AP broadcast to 16 users in NLOS environment (channel model B). Computer simulations are performed for the proposed method, ES or E_SDM in 4x4 MIMO and IEEE 802.11a standard. The two first techniques achieve a noticeable improvement over the IEEE 802.11a. ES achieves a total throughput improvement of 0.2286 in comparison to our scheme in NLOS environment. Afterwards, we consider a wireless scenario incorporating $K = 4$ users in order to compare the three techniques in LOS/NLOS environment. Angular users' direction (θ) is $0^\circ, 180^\circ, 90^\circ$ and 270° . We suppose that users are equaled by AP. Knowledge of users' direction permits gathering users in four multicast sets ($G = 4$). Figure 3 shows the average physical layer data rate as function of distance. In figure 4, each deployment of network corresponds to different locations of 4 users, randomly placed in 4 multicast groups. At the first five deployments, the range of four groups is 350-10 degrees, 80-100 degrees, 170-190 degrees and 260-280 degrees. At

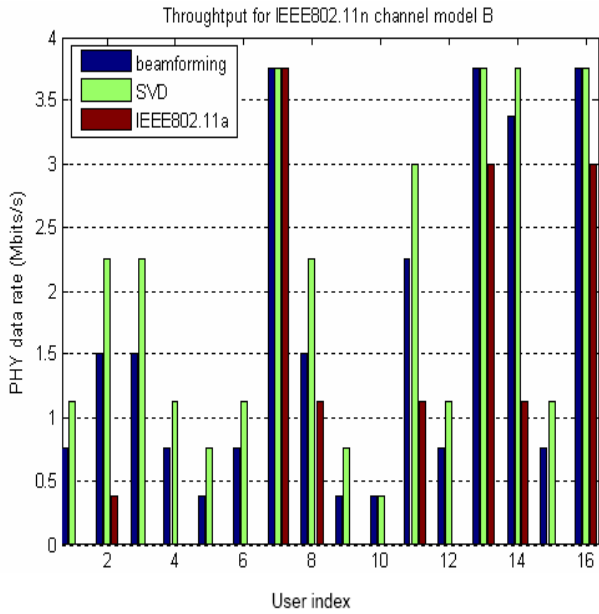

Figure 2. Throughput for channel model B

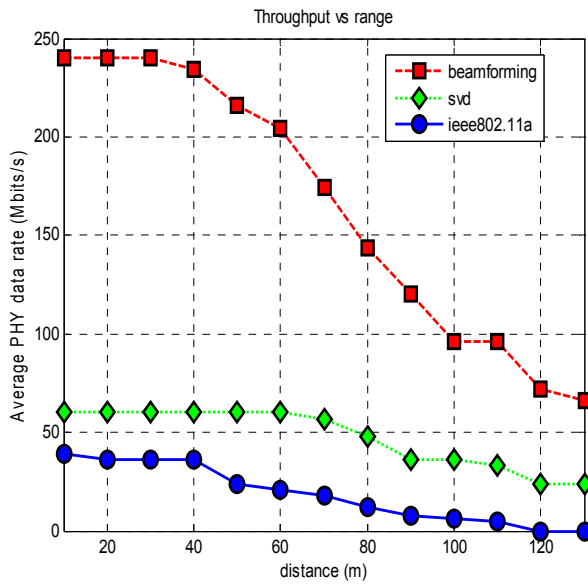

Figure 3. Throughput versus range for LOS/NLOS channel

the next five deployments, the range of groups is 340-20 degrees, 70-110 degrees, 160-200 degrees and 250-290 degrees. The final five deployments correspond to range 330-30 degrees, 60-120 degrees, 150-210 degrees and 240-300 degrees. Beam forming is optimized for $\gamma_k=20$ dB. We remark that throughput diminish as group cover bigger area. Improvement of our beamforming technique is noticeable. Channel bonding technique permits 12 zeroed sub-carriers to be used as data sub-carriers and therefore the maximum average PHY data rate for proposed scheme is 540 Mbits/s .

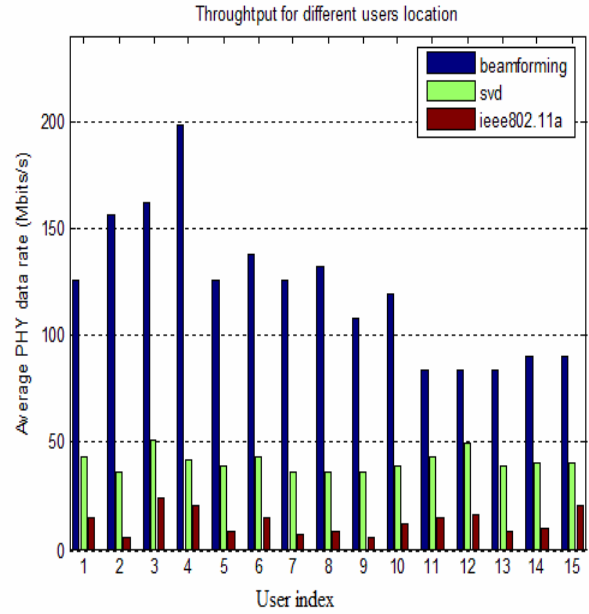

Figure 4. Average PHY data rate for different users' location.

V. CONCLUSIONS

In this paper, we studied and developed strategies compliant with IEEE 802.11n proposal. These methods use common transmission weight vectors for all sub-carriers allocated to the same set of users. Our proposed technique is a power-saving and less complex approach in comparison with E-SDM.

REFERENCES

- [1] J. M. Wilson, "The Next Generation of Wireless LAN Emerges with 802.11n", *Technology @Intel Magazine*, August 2004, pp 1-8.
- [2] IEEE 802.11 WG, "IEEE 802.11n draft 2.0" Jan. 2007.
- [3] I. Medvedev, R. Walton, J. Ketchum, S. Nanda, B. A. Bjerke, M. Wallace and S. Howard, "Transmission Strategies for High Throughput MIMO OFDM Communication", *Communications*, 2005. ICC '05, IEEE International Conference On, pp 2621-2625.
- [4] K. Miyashita, T. Nishimura, T. Ohgane, Y. Ogawa, Y. Takatori, and K. Cho, "Eigenbeam-Space Division Multiplexing (E-SDM) in a MIMO Channel", *Technical Report of IEICE, RCS2002-53*, pp. 13-18, 2002 (in Japanese).
- [5] IEEE P802.11 wireless LANs TGn Channel Models, 2004.
- [6] Jorgen Bach Andersen, "Array Gain and Capacity for Known Random Channels with Multiple Element Arrays at Both Ends", *IEEE journal on selected area in communications*, vol. 18, No 11, November 2000, pp 2172-2178.
- [7] E. Karipidis, N.D. Sidiropoulos, and Z.-Q. Luo, "Transmit Beamforming to multiple co-channel multicast groups", in *Proc. IEEE CAMSAP 2005*, Dec 12-14, Mexico.
- [8] N.D. Sidiropoulos, T.N. Davidson, and Z.-Q. Luo, "Transmit Beamforming for physical Layer Multicasting", *IEEE Trans. On Signal Processing*, vol 54, no. 6, pp 2239-2251, 2006.
- [9] J.F. Sturm, "Using SeDuMi 1.02, a MATLAB Toolbox for optimization over symmetric cones", *Optimization Methods and Software*, vol 11-12, pp 625-653, 1999
- [10] L. Schumacher, "WLAN MIMO Channel Matlab program", download: http://www.info.fundp.ac.be/~lsc/Research/IEEE_802.11_HTSG_CMSC/distribution_terms.html